

## CBD15J/18J/20J-Li2 Lithium Battery Powered Pallet Truck

### Characteristics:

- The truck is simple and dexterous, with small turning radius and small weight. It is suitable for ultra-narrow channel operation.
- The truck has compact and reliable structure. The oil pipeline and line are wrapped in the truck body which is safe and beautiful and convenient for user maintenance.
- The truck adopts integrated handle design integrating key switch and electric meter which is simple and comfortable for operation.
- Hand-held lithium battery makes battery changing easier and more convenient.
- Standard configuration of emergency stop switch and emergency reverse device ensure truck safety.
- The truck is assembled with power-off braking function. The truck is braked as soon as the handle is loosened or pressed to the bottom.
- Electromagnetic braking and motor braking are used to ensure the safety of driving.



## CBD15J/18J/20J-Li2

### Manufacturer's Data and Design Characteristics

Characteristics		HELI	HELI	HELI	
1.1	Manufacturer	HELI	HELI	HELI	
1.2	Model	CBD15J-Li2	CBD18J-Li2	CBD20J-Li2	
1.3	Type of operation	Pedestrian	Pedestrian	Pedestrian	
1.4	Rated capacity	Q (kg)	1500	1800	2000
1.5	Lift height	h3 (mm)	200	200	200
1.6	Service weight with battery	kg	138	140	145
1.7	Load centre	c (mm)	600	600	600
1.8	Axle centre to fork face	x (mm)	944	944	944
1.9	Wheel base	y (mm)	1184	1184	1184
1.10	Controller		CURTIS	CURTIS	CURTIS
Wheels					
2.1	Wheels type		Polyurethane	Polyurethane	Polyurethane
2.2	Driving wheels size	Φ × w (mm)	Φ210 × 70	Φ210 × 70	Φ210 × 70
2.3	Loading wheels size	Φ × w (mm)	Φ80 × 60	Φ80 × 60	Φ80 × 60
2.4	wheels, number front/rear (x = driven)		1x/4	1x/4	1x/4
2.5	track width, rear, loading side	b11 (mm)	400/535	400/535	400/535
Dimensions					
3.1	Overall length	l1 (mm)	1543	1543	1543
3.2	Length to fork face	l2 (mm)	393	393	393
3.3	Overall width	b1 (mm)	550/685	550/685	550/685
3.4	Fork dimensions	s/e/l (mm)	50/150/1150	50/150/1150	50/150/1150
3.5	Width of forks	b5 (mm)	550/685	550/685	550/685
3.6	Lowered height	h13 (mm)	85	85	85
3.7	Min. Ground clearance	m2 (mm)	35	35	35
3.8	Height drawbar in driving position min./max.	h14 (mm)	830/1120	830/1120	830/1120
3.9	Aisle width with pallet 1000 x 1200 across forks	Ast (mm)	1760	1760	1760
3.10	Aisle width with pallet 800 x 1200 along forks	Ast (mm)	1810	1810	1810
3.11	Min. Turning radius	Wa (mm)	1355	1355	1355
Performance					
4.1	Travel speed, with/without load	(km/h)	4.2/4.5	4.2/4.5	4.2/4.5
4.2	Max. Gradeability laden/unladen	(%)	5/10	4/10	6/10
4.3	Service brake type		Electromagnetic brake	Electromagnetic brake	Electromagnetic brake
Drive and Battery					
5.1	Drive motor, output s2 60 min.	(kW)	0.75	0.75	0.75
5.2	Lift motor rating at s3 15%	(kW)	0.8	0.8	0.8
5.3	Battery according to din 43531/35/36 a,b,c,no		no	no	no
5.4	Battery voltage/rated capacity	(V/Ah)	24/28 (LFP)	24/28 (LFP)	48/20 (LFP)
5.5	Battery weight (± 5%)	(kg)	6.8	6.8	7.5
5.6	Charger specification		24V/10A (LFP)	24V/10A (LFP)	48V/5A (LFP)
Others					
6.1	Type of drive control		DC	DC	DC
6.2	Sound pressure level at driver's ear	(dB(A))	≤ 70	≤ 70	≤ 70
6.3	Steering type		Mechanical steering	Mechanical steering	Mechanical steering

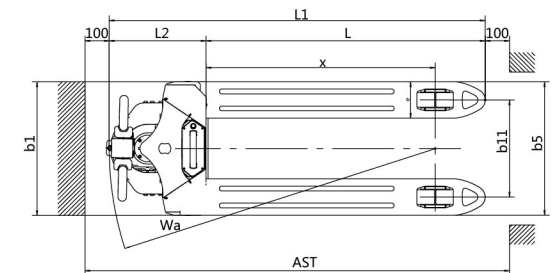
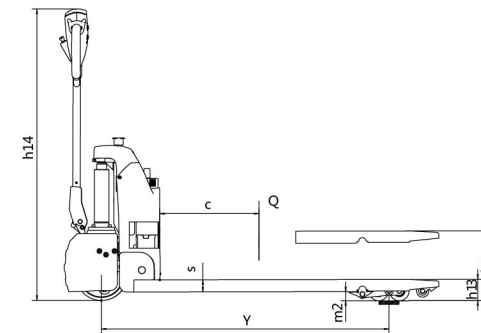

**ANHUI HELI CO., LTD.**

Add / No.668, FangXing Road, Hefei, China  
Fax / +86-551-63639966

Tel / +86-551-63639068(America); 63639258(Europe);  
63639358(Asia); 63662105(Africa & Middle East);  
63639530(Key Accounts Division); 63662105(Wheel loader)